



# Maximo®

Összeszerelési és használati utasítás



**1**  
Ergonomikusan  
formázott kárpitozás

**5**  
Skála

**2**  
Levehető kárpit

**6**  
Egyszerű ülés és  
háttámla magasságállítás

**3**  
2 rejtett tároló

**7**  
Biztonságos támaszték

**4**  
Combi, univerzális  
görgők

**8**  
A forgózámoly  
reteszelve

Maximo  
座椅的优点

Caratteristiche della Maximo  
Características del Maximo  
Преимущества Maximo:

Die Produktvorteile von Maximo  
Characteristics of Maximo  
Caractéristiques de Maximo

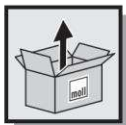

Csomagolja ki a doboz tartalmát, és ellenőrizze, hogy meg van-e minden.



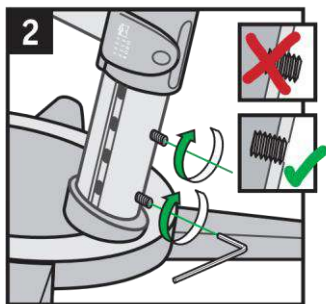
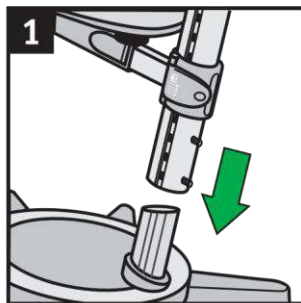
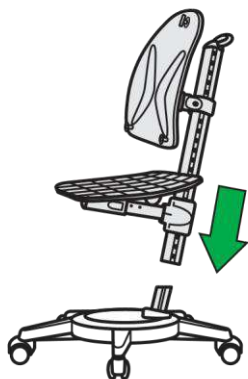

Hajtsa be a határozottan a csavarokat; az esetlegesen ilyenkor hallható zajoknak nincs jelentősége.

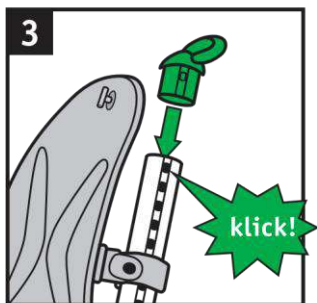

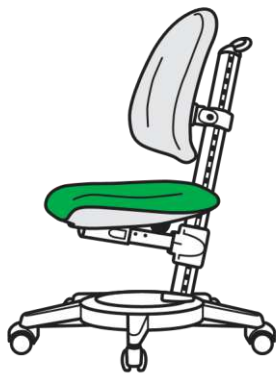
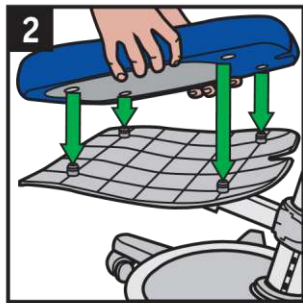
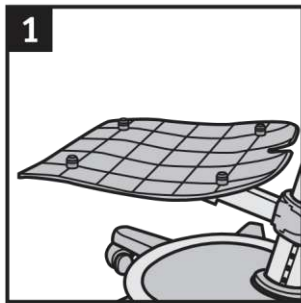

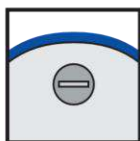
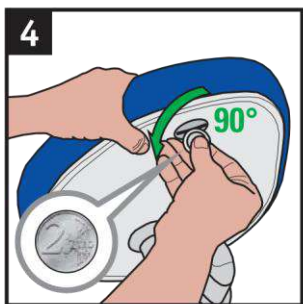
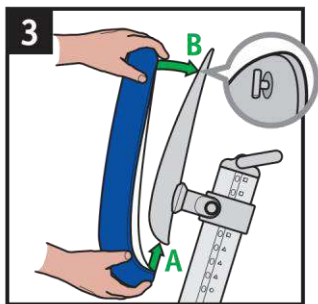
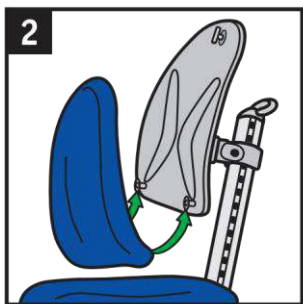
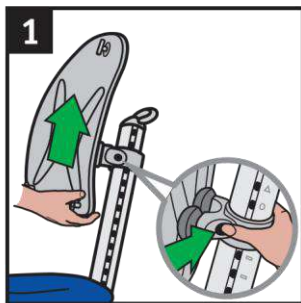

nyitva



zárva

靠背的组装

Montaggio dello schienale  
Montaje del acolchonado del respaldo  
Монтаж спинки

Montage der Rückenlehne  
Assembly of back  
Montage du dossier

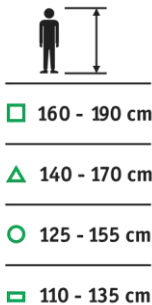
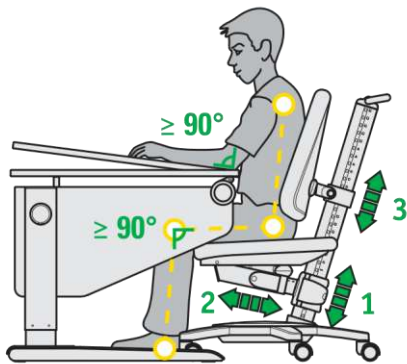

Az ülőrészt (1) állítsa a testmagassághoz (a térdhajlatnál 90°). Az ülésmélység (2) és háttámla (3) állításhoz használja a magassági skálát.



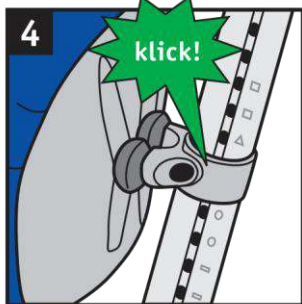
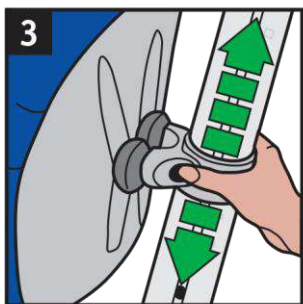
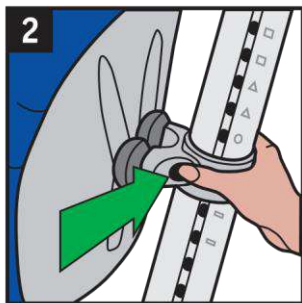
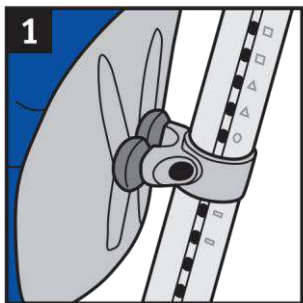
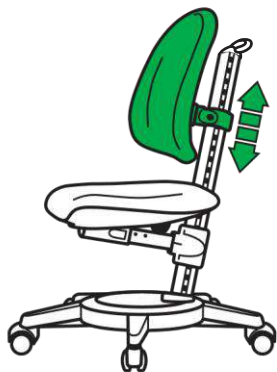

靠背的调高

Regolazione altezza schienale  
Ajuste de la altura del respaldo  
Регулировка высоты спинки

Höhenverstellung der Rückentlehne  
Height adjustment of the back  
Réglage en hauteur du dossier

Höhenverstellung der Sitzfläche  
Height adjustment of the seat  
Réglage en hauteur de l'assise

Regolazione altezza seduta  
Ajuste de la altura del asiento  
Регулировка сиденья по высоте

椅面的调高

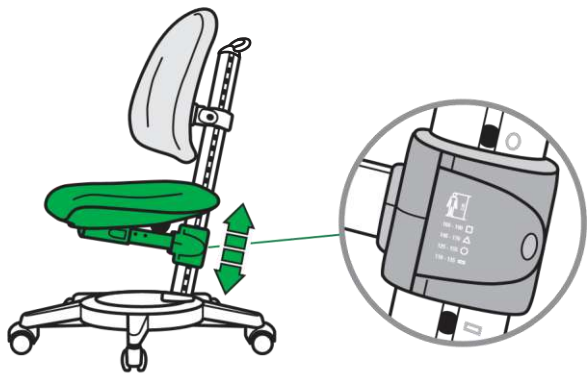
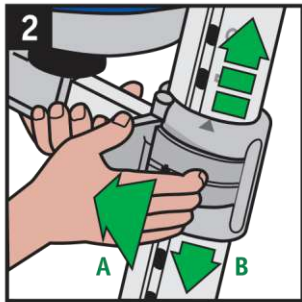
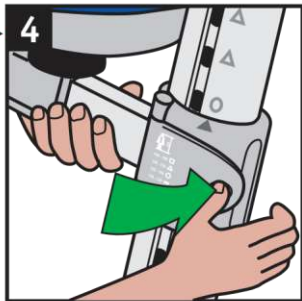
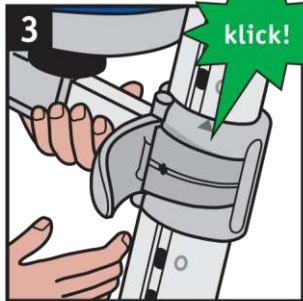



## 椅面的调深

Regolazione profondità' seduta  
Ajuste de la profundidad del asiento  
Регулировка глубины сиденья

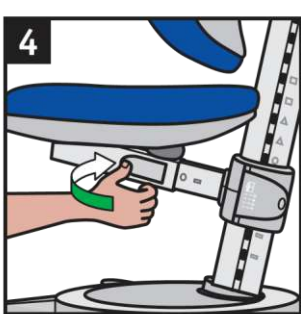
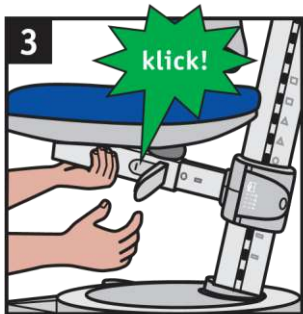
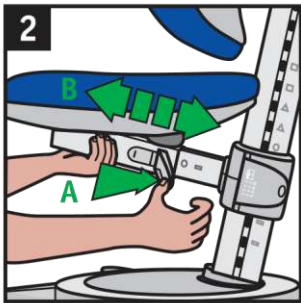
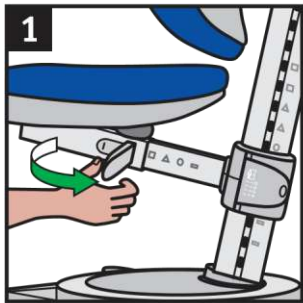

Tiefenverstellung der Sitzfläche  
Depth adjustment of the seat  
Réglage en profondeur de l'assise

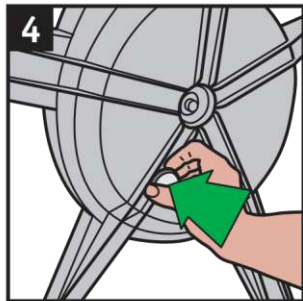
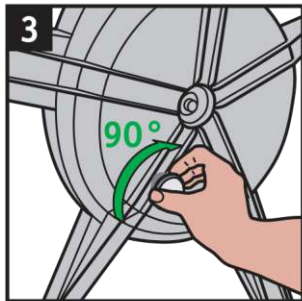
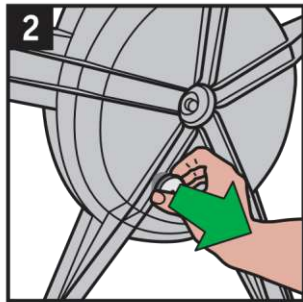
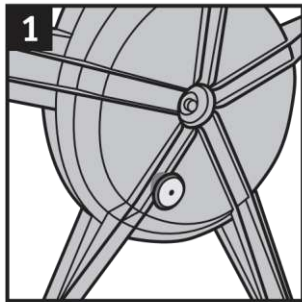

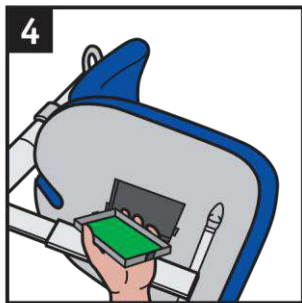
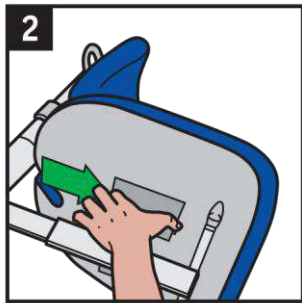
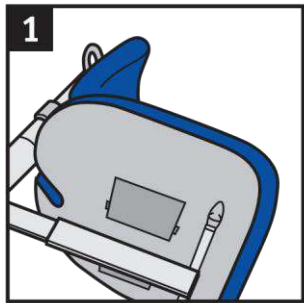
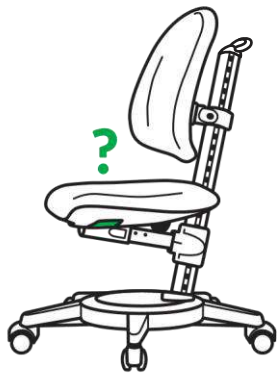

暗盒

Scompartimento segreto  
Compartimentos secretos  
Потайные отсеки

Die Geheimfächer  
Secret compartments  
Compartiments secrets

Überziehen des Rückenpolsters  
Covering back cushion  
Pose du revêtement du dossier

Rivestimento dello schienale  
Recubrir el acolchonado del respaldo  
Надевание чехла спинки

套上靠背  
垫的外罩

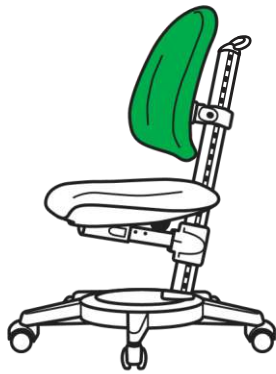
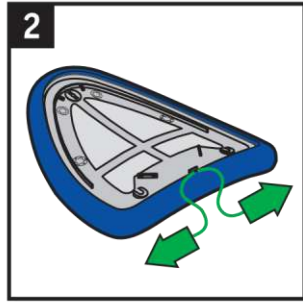
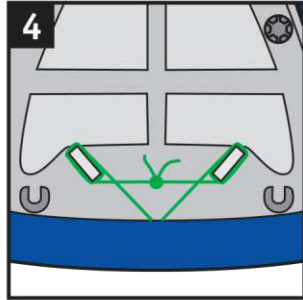
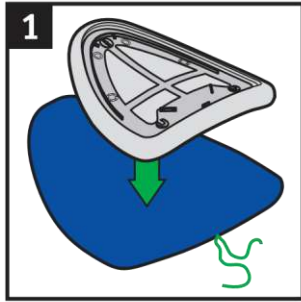
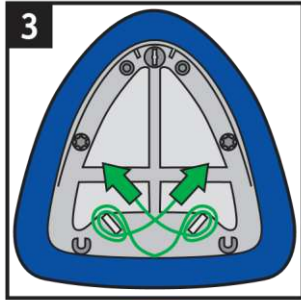

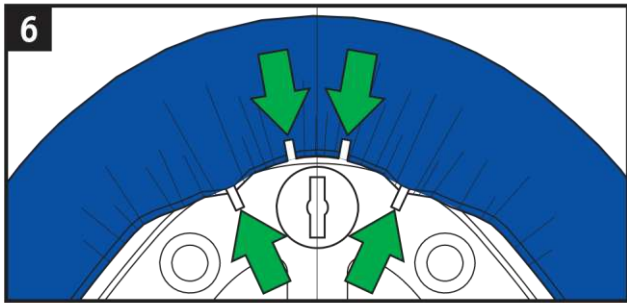
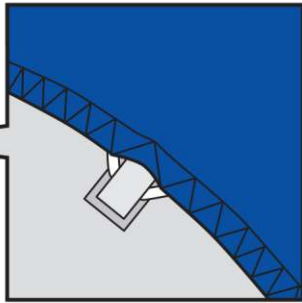

Überziehen des Rückenpolsters  
Covering back cushion  
Pose du revêtement du dossier

Rivestimento dello schienale  
Recubrir el acolchonado del respaldo  
Надевание чехла спинки

套上靠背  
垫的外罩

6 Abnehmen der Bezüge zur Reinigung  
Removing the fabrics for washing  
Déhousseage des tissus pour nettoyage

Amovibilita' del tessuto per il lavaggio  
Quitar la tela para el lavado  
Снятие чехлов для чистки

拆洗外罩

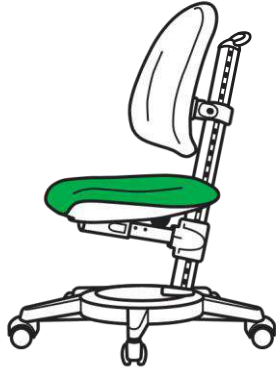
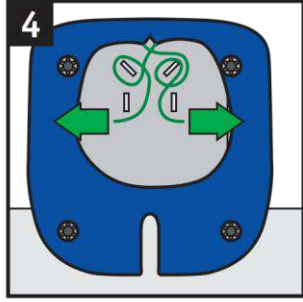
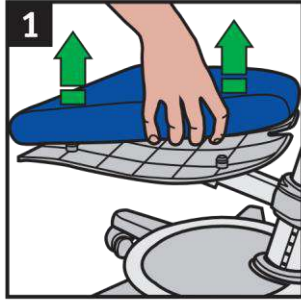
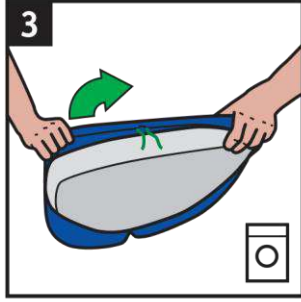



- Szövet  
Mossa 40°C-on  
kímélő mosószerrel



Kímélő mosás



Vasalni tilos



Klórmentes mosószer



Szárítógépben  
ne szárítsa



Vegyztisztítani tilos



- 
- Maximo – talpak:  
A görgők talpakra cserélhetők.  
Fekete műanyagból erős acél csappal.



Szőnyeg

- Információ:  
A görgők nem forognak a szék megterhelése nélkül, ezért a padlón nyomot vagy karcot okozhatnak laminált padlón vagy parkettán.

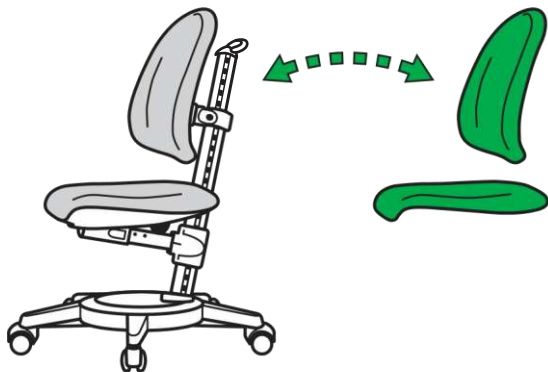

- A kárpit levehető a kicseréléshez:  
Több színben és mintában talál szöveteket a moll katalógusban.  
Kérjük keresse moll-kereskedőjét.



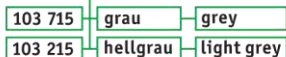
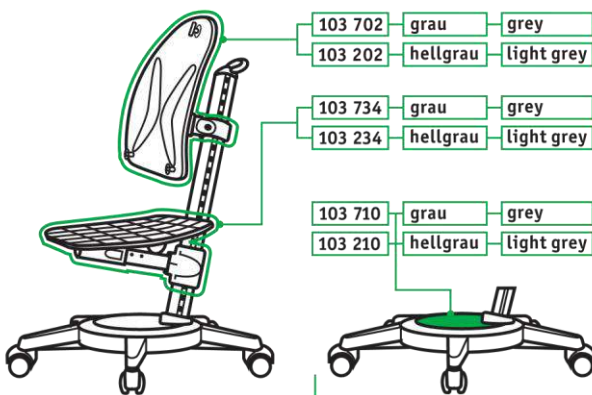
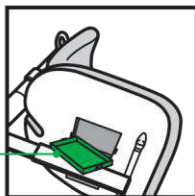
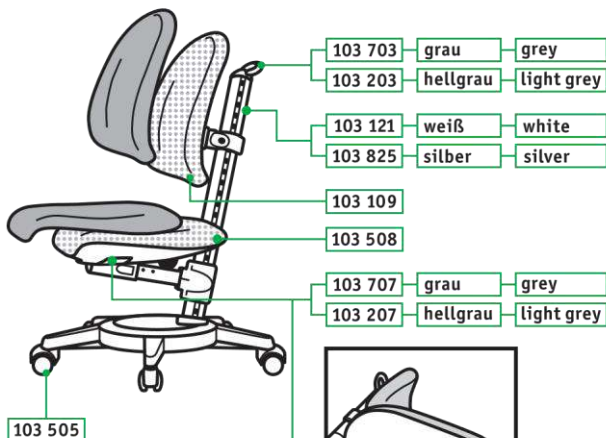

Kérjük őrizze meg ezt az összeszerelési és használati utasítást.



www.tuv.com  
ID 1000000000

Biztonsági tanúsítás

5 év minőségi garancia\*

\*A moll garanciális feltételek szerint



品质保证\*

Garanzia\*  
Garantia\*  
Гарантийный пакет\*

Garantiepaket\*  
Warranty\*  
Garantie\*

moll Funktionsmöbel GmbH  
Rechbergstraße 7  
D-73344 Gruibingen  
service@moll-funktion.de

Moll-bútor Internetes Áruház  
+36 20 914 3350  
<https://bolt.mollbutor.hu>

[www.moll-funktion.de](http://www.moll-funktion.de)